

# BLADDER TANK (CAPTIVE AIR) COMPOSE IT™



## GENERAL OVERVIEW

Composite tank with captive air bladder (air contained inside the bladder) adapted for **water pressure installations** using any type of pump (domestic, agricultural, industrial, commercial and community applications)

**Tanks from 60 to 450 liters:** Pipe fittings from DN 32 (1<sup>1</sup>/<sub>4</sub>) to DN 65 (2<sup>1</sup>/<sub>2</sub>)  
**Working pressure 8 bar:** hydraulic pressure test: 12 bar; burst pressure > 30 bar  
 Compliant with the European Pressure Equipment Directive 2014/68/EU

Extreme lifetime

Bladder designed to resist

Bladder replacement in 5 minutes

Ultra light tank

Tank warranty : 10 years ; bladder warranty : 2 years

Multiple connections configuration

Limited, easy and cost effective maintenance

## ADVANTAGES

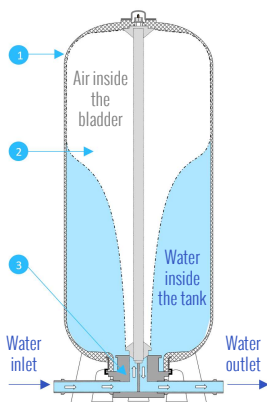

- 1 Extreme lifetime**  
Tank warranty 10 years. Maintenance free. Patented Compose It™ technology for an improved mechanical resistance. Composite monolithic structure without any welded part, raw materials selected for their extreme durability (High fatigue resistance to cycling, 100% corrosion free).
- 2 Bladder design to resist**  
Polyurethane bladder with a long service time (compressed air inside the bladder). The bladder volume is greater than the tank volume (to avoid mechanical stress on the bladder).
- 2 Bladder replacement in 5 minutes**  
Wide opening of 160 mm diameter opening, with lower PVC lid fixed with a stainless steel clamp allowing **an easy and quick access** to the inside of the tank and a bladder change in 5 minutes after emptying the tank.
- 3 Customisation of pipe fittings**  
3 configurations of fittings DN32 (1<sup>1</sup>/<sub>4</sub>) are available to suit all installation configurations: 1 elbow, 2 Tee fittings with or without separate wall between the water inlet and outlet.

## INNOVATIVE BLADDER DESIGNED TO RESIST



The innovative bladder has been specially designed for Compose It™ tanks, to guarantee a long operational life.

The polyurethane polymer has been selected and formulated to provide the bladder with excellent mechanical properties, high abrasion resistance and a high tightness. **The volume of the bladder, greater than the tank volume,** avoid bladder expansion in operation.

To go even further in performance, **the air is compressed inside the bladder,** which limits the stresses, and therefore the thickness of the bladder, for an optimized usable water volume.

All Compose It™ bladders are tested at 2 bar before assembling to ensure quality.

## BLADDER REPLACEMENT IN 5 MINUTES

Tank conception has been designed to easily and quickly replace the bladder in order to **decrease maintenance cost**, and take advantage of the extreme long lifetime of the tank made of selected composite materials.

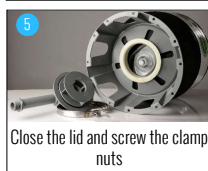
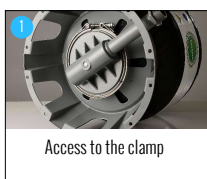

## THE MOST ECONOMICAL SOLUTION OVER TIME

**Decomposition of the average cost of use of a bladder/membrane tank**

Period of use : 20 years : 100% base : metallic bladder tank.

From left to right : Installation cost / Maintenance cost (bladder tanks) / Total cost

	25%	25%	50%
Compose It bladder tanks			
Composite membrane tank		72%	72%
Composite bladder tank	63%	13%	76%
Metallic membrane tank		82%	82%
Metallic bladder tank	65%	35%	100%

# BLADDER TANK (CAPTIVE AIR) COMPOSE IT™



## SPECIFICATIONS

Tanks	Volume (Liters)	Weight* (kg)	Dimensions* (mm)				
			H	h	D	d	a
Bladder tank (captive air) 60 L	60	9,9	650	555	460	160	13
Bladder tank (captive air) 115 L	115	13,1	975	880	460	160	13
Bladder tank (captive air) 150 L	150	16,3	1 220	1110	460	160	13
Bladder tank (captive air) 230 L	230	22,0	1 070	910	610	160	13
Bladder tank (captive air) 300 L	300	23,4	1 315	1 200	610	160	13
Bladder tank (captive air) 450 L	450	31,1	1 825	1 710	610	160	13

Minimum operating temperature of 1 °C, Maximum operating temperature of 50 °C. Maximum working pressure of 8 bar.

Bladder initial preload at 1,3 bar. Bladder tank compliant with the European Pressure Equipment Directive 2014/68/EU

\* Diameter, height and weight are subject to change without previous notice

## IN OPERATION

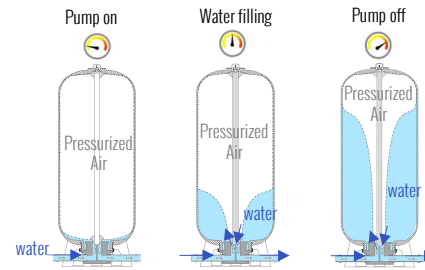

Compose It™ bladder tanks pressure cycle

The air pressurized inside the bladder, gradually increases in pressure as the tank is filled with water. In operation, the pressurized air in the bladder is pushing out the water from the tank. This system offers a higher flexibility in the pressure range settings to maximize the useful volume of water inside a Compose It™ tanks.

## DESCRIPTION

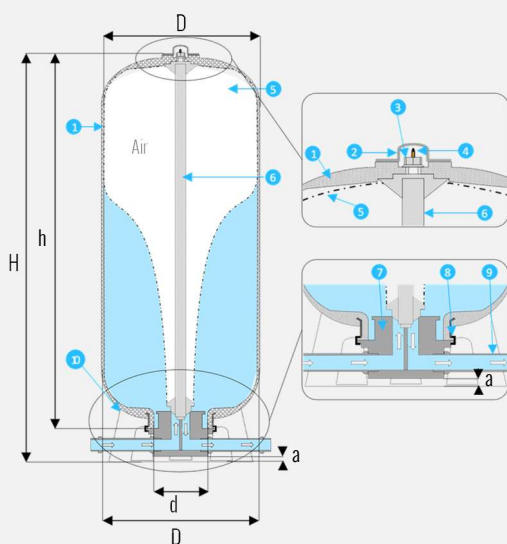

- 1 Tank in recyclable thermoplastic composite materials reinforced with glass fibers (monolithic structure with improved mechanical properties) with an extreme lifetime, high fatigue resistance to cycling and 100% corrosion free. Tank compliant with chemical agents, aggressive and saline waters
- 2 PVC valve protection cap
- 3 Valve fixing nut
- 4 Air valve connected to the bladder
- 5 Polyurethane bladder with pressurized air inside
- 6 PVC tube to maintain the bladder position
- 7 PVC lid with 160mm of diameter easy to remove
- 8 Stainless steel clamp fixed with a nut, simple and quick to use
- 9 3 configurations of fittings: Elbow, Tee with or without wall separation between the water inlet and outlet (see details on the right boxes)
- 10 PVC support

## OPTIONS

### Elbow fitting

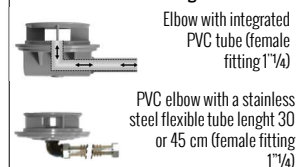

Elbow with integrated PVC tube (female fitting 1"¼)

PVC elbow with a stainless steel flexible tube length 30 or 45 cm (female fitting 1"¼)

### Tee fitting

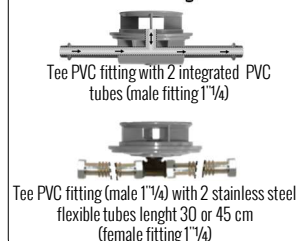

Tee PVC fitting with 2 integrated PVC tubes (male fitting 1"¼)

Tee PVC fitting (male 1"¼) with 2 stainless steel flexible tubes length 30 or 45 cm (female fitting 1"¼)

### Tee fitting with separation

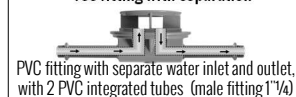

PVC fitting with separate water inlet and outlet, with 2 PVC integrated tubes (male fitting 1"¼)

Horizontal version on request

## AN OPTIMIZED USEFUL WATER VOLUME

The design of the Compose It™ bladder (air in the bladder and bladder volume > tank volume) allows a higher operational pressure differential range (between switching on and off of the pump) in order to maximize the useful water volume of Compose It™ tanks. Thus, in terms of useful water volume, **a 1,000 liters without bladder tank is equivalent to a 300 liters bladder or diaphragm tank, or a 230 liters Compose It™ bladder tank**, as detailed below:

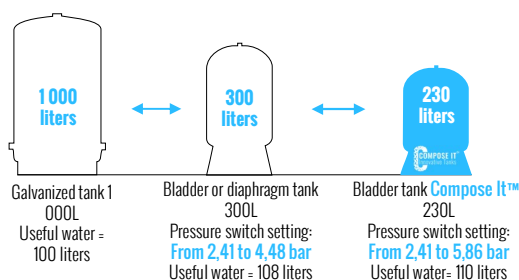

## COMPOSE IT™ BLADDER TANK DRAWDOWN FACTORS

Switch on pump pressure - bar

bar	1,37	1,72	2,06	2,41	2,75	3,10	3,44	3,79	4,13	4,48	4,82	5,17	5,51	5,86	6,20	6,55	6,89	7,23	
2,06	21																		
2,41	28	19																	
2,75	34	26	17																
3,10	39	32	24	16															
3,44	44	37	30	22	15														
3,79	47	41	34	28	21	14													
4,13	50	44	38	32	26	19	13												
4,48	53	48	42	36	30	24	18	12											
4,82	56	50	45	41	34	29	23	17	11										
5,17		53	48	43	38	32	27	22	16	11									
5,51			50	46	41	36	31	26	21	15	10								
5,86				48	43	39	34	29	24	20	15	10							
6,20					46	42	37	32	28	23	19	14	9						
6,55						44	41	35	31	27	22	18	13	9					
6,89							42	38	34	30	26	21	17	13	9				
7,23								41	37	33	29	25	20	16	13	8			
7,52									39	35	31	27	24	20	16	12	8		
7,92										38	34	30	26	23	19	15	11	8	

All the values are calculated with a preload pressure 0,3 bar below the desired switch on pump pressure. A lower preload pressure may be desired to increase the outlet flow rate. In accordance with state of the art industry standards, drawdown ratios are based on Boyle-Mariotte law. Drawdown factors may slightly vary depending on system accessories, including accuracy of the pressure switch, the pressure gauge and water temperature.